

APPLICATION NOTE

Document NO. AN-UHF-078-A
 Date : 26th Sep. 2006
 Rev. date : 7th Jan. 2010
 Prepared : K. Mori
 Confirmed : S.Kametani
 (Taking charge of Silicon RF by
 MIYOSHI Electronics)

SUBJECT: Electro Static Sensitivity for RA60H4452M1 and RA60H4047M1

GENERAL:

RA60H4452M1 and RA60H4047M1 use MOS FET device.

MOS FET devices have lower surge endurance compared with silicon bipolar devices. And there is a possibility of burn-out when static electricity or surge is added to devices.

This application note shows the test results of the electro static discharge level for RA60H4452M1 and RA60H4047M1.

1. ELECTRO STATIC DISCHARGE TEST RESULTS:

-1. Test Block Diagram;

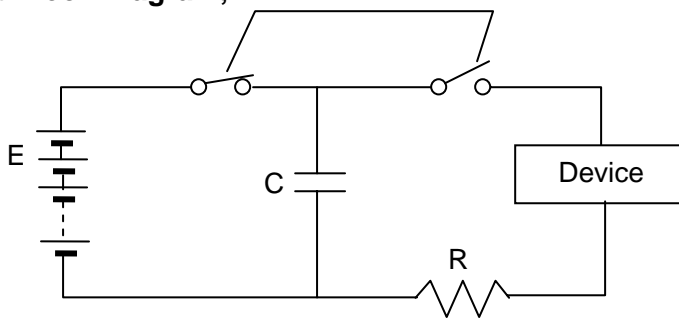

-2. Pinning;

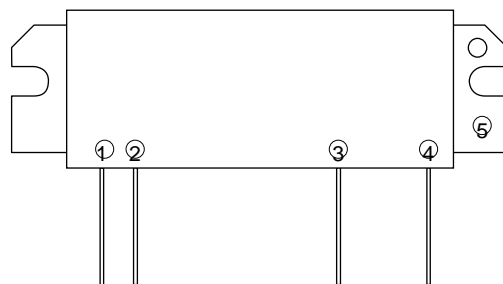

- 1 RF Input (P_{in})
- 2 Gate Voltage (V_{GG})
- 3 Drain Voltage (V_{DD})
- 4 RF Output (P_{out})
- 5 RF Ground (Flange)

(Block Diagram)

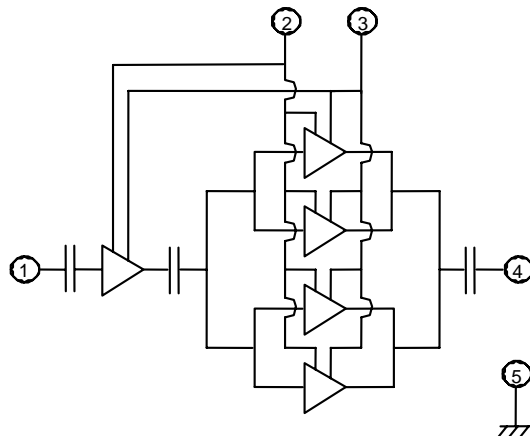

-3. Human Model Test Results;

[Type number: RA60H4452M1 (Po>60W @440-520MHz, Vdd=12.5V)]

Test Conditions are;

C=100pF, R=1.5KΩ, 3 times discharge for one Voltage,

E=100V step increasing (Max. 6000V)

Terminal	Polarity	Sample NO.	Destroyed Voltage(V)	Polarity	Sample NO.	Destroyed Voltage(V)
Pin to Flange	+	1	1400	-	1	-2700
		2	1400		2	-2600
		3	1500		3	-2600
Vgg to Flange	+	1	Over 6000	-	1	Over -6000
		2	Over 6000		2	Over -6000
		3	Over 6000		3	Over -6000
Vdd to Flange	+	1	Over 6000	-	1	Over -6000
		2	Over 6000		2	Over -6000
		3	Over 6000		3	Over -6000
Pout to Flange	+	1	Over 6000	-	1	Over -6000
		2	Over 6000		2	Over -6000
		3	Over 6000		3	Over -6000

NOTE: Test of RA60H4047M1 that is derivative from RA60H4452M1 is omitted for the same type under this test.