

# APPLICATION NOTE



## **RF POWER SEMICONDUCTORS**

Document NO. AN-UHF-027-C  
Date : 16<sup>th</sup> Oct. 2003  
Rev.date : 7<sup>th</sup> Jan. 2010  
Prepared : M.Wada  
                  S.Kametani  
Confirmed : T.Okawa  
(Taking charge of Silicon RF by  
                  MIYOSHI Electronics)

**SUBJECT:** RD07MVS1 RF characteristics data

### **SUMMARY:**

This application note show the RF Wide band DUT characteristics data (Po vs. Frequency characteristics) with RD07MVS1.

- Sample history :  
    RD07MVS1: Lot number "031AA"
  
- Evaluate conditions :  
    @f=450-520MHz : Vdd=7.2V, Idq=0.75A (Vgg adj.)
  
- Results :  
    Page 2-4 shows the RF characteristics (Po vs. Frequency characteristics) data.  
    Page 5 shows the RF characteristics (Po=7W constant,  $\eta_d$  characteristics) data.  
    Page 6 shows the Equivalent Circuit.

RD07MVS1 Frequency vs.  $P_o$ ,  $\eta_d$  characteristics (@  $f=450\text{-}520\text{MHz}$ )

Pin=0.7 / 1.0 / 1.2 / 1.5W

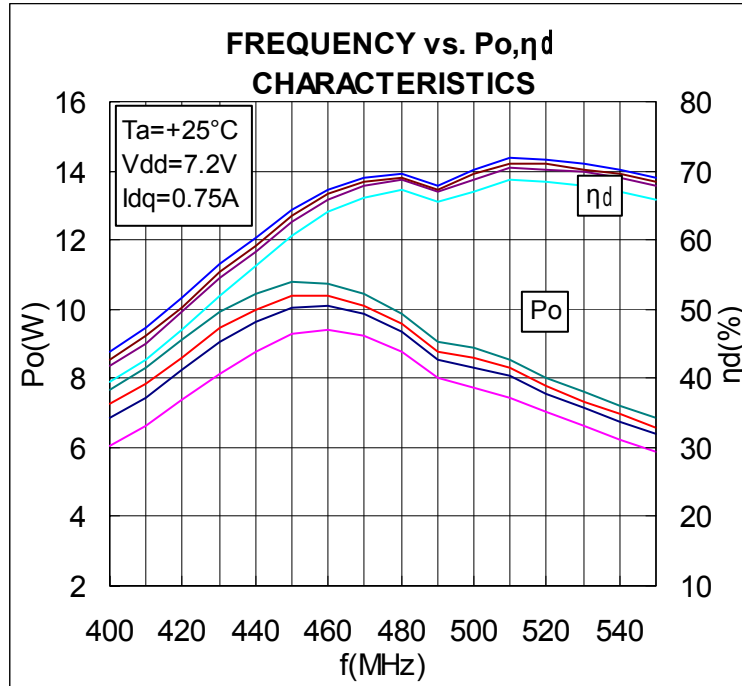
RD07MVS1 Frequency vs.  $P_o$ ,  $\eta_d$  characteristics (@Pin=0.7W,  $f=450\text{-}520\text{MHz}$ )

f(Hz)	Pin(W)	Po(W)	Idd(A)	d(%)	R.L(dB)	Harmonics 2fo(dBc)	Harmonics 3fo(dBc)
400	0.701	5.81	2.124	37.98	-2.10	-27.17	-52.37
410	0.706	6.43	2.148	41.57	-2.35	-27.79	-48.70
420	0.704	7.17	2.172	45.83	-2.63	-28.53	-51.69
430	0.695	7.91	2.178	50.42	-3.07	-28.94	-53.33
440	0.697	8.61	2.166	55.21	-3.56	-29.59	-55.23
450	0.701	9.10	2.120	59.63	-4.11	-29.07	-56.14
460	0.706	9.30	2.039	63.31	-4.53	-28.39	-56.01
470	0.692	9.12	1.933	65.55	-4.62	-27.27	-56.21
480	0.697	8.68	1.813	66.47	-4.46	-25.29	-56.14
490	0.697	8.01	1.696	65.62	-4.15	-23.90	-55.38
500	0.696	7.79	1.604	67.45	-3.67	-24.68	-55.38
510	0.694	7.55	1.511	69.39	-3.15	-29.44	-53.67
520	0.702	7.17	1.425	69.87	-2.82	-33.68	-52.42
530	0.705	6.76	1.355	69.30	-2.51	-38.44	-51.98
540	0.704	6.37	1.293	68.47	-2.29	-41.86	<-60
550	0.702	6.00	1.238	67.35	-2.09	-44.06	<-60

RD07MVS1 Frequency vs. Po,  $\eta$ d characteristics (@Pin=1.0W, f=450-520MHz)

f(Hz)	Pin(W)	Po(W)	Idd(A)	d(%)	R.L(dB)	Harmonics 2fo(dBc)	Harmonics 3fo(dBc)
400	1.003	6.61	2.283	40.20	-1.91	-28.48	-52.47
410	0.997	7.24	2.294	43.83	-2.20	-29.50	-48.50
420	1.010	8.05	2.318	48.20	-2.48	-29.98	-50.68
430	1.008	8.82	2.318	52.84	-2.90	-30.82	-52.28
440	0.990	9.44	2.286	57.34	-3.46	-30.87	-54.40
450	0.995	9.86	2.225	61.52	-3.94	-29.89	-55.70
460	0.989	9.96	2.127	65.00	-4.37	-28.60	-54.58
470	0.997	9.76	2.018	67.20	-4.51	-26.89	-55.96
480	1.009	9.25	1.892	67.91	-4.46	-24.78	-55.56
490	1.008	8.56	1.775	67.01	-4.21	-22.99	-54.68
500	0.996	8.39	1.682	69.29	-3.56	-23.91	-55.12
510	1.008	8.16	1.588	71.34	-3.21	-28.47	-53.92
520	1.006	7.72	1.497	71.65	-2.86	-32.48	-52.24
530	1.010	7.30	1.423	71.22	-2.55	-36.83	-51.72
540	0.999	6.89	1.360	70.32	-2.24	-40.04	<-60
550	0.999	6.51	1.306	69.22	-2.09	-42.27	<-60

RD07MVS1 Frequency vs. Po,  $\eta$ d characteristics (@Pin=1.2W, f=450-520MHz)

f(Hz)	Pin(W)	Po(W)	Idd(A)	d(%)	R.L(dB)	Harmonics 2fo(dBc)	Harmonics 3fo(dBc)
400	1.210	7.01	2.361	41.22	-1.93	-29.30	-51.86
410	1.192	7.63	2.364	44.82	-2.16	-30.20	-48.17
420	1.186	8.37	2.374	48.96	-2.53	-30.79	-50.75
430	1.192	9.16	2.372	53.64	-2.90	-31.75	-52.68
440	1.191	9.80	2.338	58.22	-3.41	-31.47	-54.46
450	1.195	10.18	2.269	62.29	-3.88	-30.20	-55.61
460	1.209	10.25	2.168	65.67	-4.34	-28.60	-55.28
470	1.203	10.02	2.054	67.72	-4.43	-26.75	-56.45
480	1.203	9.46	1.922	68.35	-4.32	-24.42	-55.73
490	1.191	8.76	1.805	67.41	-4.03	-22.65	-54.67
500	1.204	8.65	1.717	69.99	-3.52	-23.57	-54.21
510	1.205	8.39	1.619	71.95	-3.21	-28.24	-53.61
520	1.214	7.97	1.530	72.38	-2.84	-32.06	-52.07
530	1.188	7.50	1.452	71.69	-2.52	-36.26	-52.00
540	1.199	7.11	1.393	70.91	-2.30	-39.32	-52.14
550	1.205	6.73	1.338	69.89	-2.07	-41.74	<-60

RD07MVS1 Frequency vs.  $P_o$ ,  $\eta_d$  characteristics (@ $P_{in}=1.5W$ ,  $f=450-520MHz$ )

f(Hz)	$P_{in}(W)$	$P_o(W)$	$I_{dd}(A)$	$\eta_d(\%)$	R.L(dB)	Harmonics 2fo(dBc)	Harmonics 3fo(dBc)
400	1.488	7.39	2.433	42.20	-1.86	-30.13	-51.54
410	1.505	8.08	2.446	45.89	-2.06	-31.42	-48.18
420	1.496	8.86	2.453	50.19	-2.43	-32.18	-50.81
430	1.513	9.65	2.447	54.78	-2.88	-32.88	-52.16
440	1.513	10.27	2.406	59.29	-3.28	-32.27	-54.34
450	1.489	10.57	2.323	63.19	-3.83	-30.55	-55.18
460	1.499	10.58	2.214	66.39	-4.19	-28.58	-55.29
470	1.509	10.33	2.097	68.42	-4.36	-26.51	-56.68
480	1.497	9.73	1.961	68.91	-4.29	-24.29	-55.67
490	1.505	9.05	1.848	67.99	-3.96	-22.37	-55.16
500	1.509	8.95	1.756	70.79	-3.50	-23.18	-55.48
510	1.495	8.66	1.654	72.75	-3.16	-27.60	-53.41
520	1.498	8.21	1.562	73.02	-2.81	-31.52	-52.35
530	1.501	7.77	1.489	72.46	-2.50	-35.74	-52.11
540	1.485	7.36	1.428	71.55	-2.25	-38.78	<-60
550	1.502	6.98	1.375	70.52	-2.09	-41.15	<-60

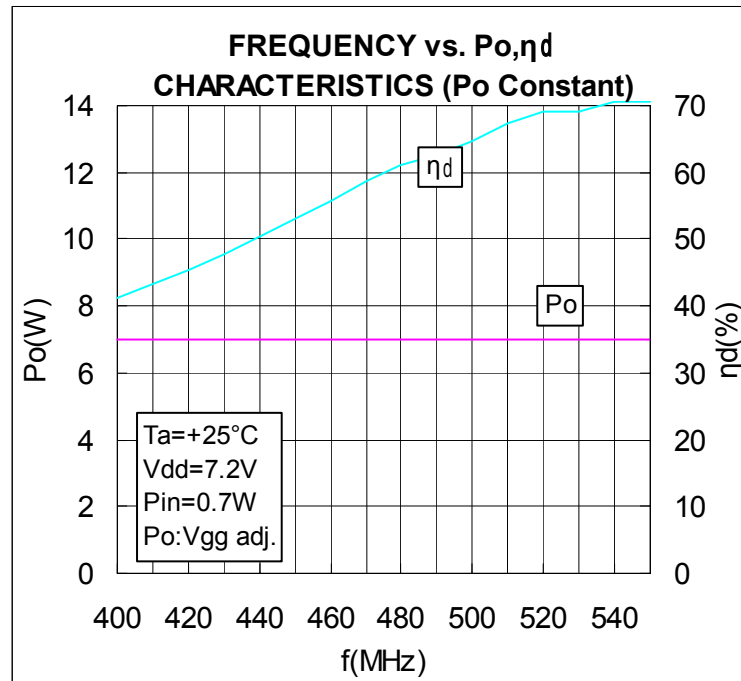
RD07MVS1 Frequency vs.  $\eta_d$  characteristics (@ f=450-520MHz and  $P_o=7W$  constant)

f(GHz)	Pin(W)	Po(W)	Idd(A)	d(%)	Harmonics 2fo(dBc)	Harmonics 3fo(dBc)
400	1.301	6.99	2.356	41.19	-29.67	-51.68
410	0.913	7.00	2.251	43.17	-28.94	-48.69
420	0.671	7.01	2.144	45.38	-28.26	-51.38
430	0.507	6.99	2.034	47.75	-27.67	-53.21
440	0.402	7.01	1.932	50.36	-27.25	-54.80
450	0.336	7.02	1.835	53.13	-27.14	<-60
460	0.296	6.98	1.736	55.83	-26.75	<-60
470	0.293	7.01	1.660	58.66	-26.64	<-60
480	0.320	7.01	1.593	61.11	-25.70	<-60
490	0.407	6.99	1.554	62.44	-24.95	<-60
500	0.475	7.01	1.507	64.58	-25.76	<-60
510	0.524	6.99	1.443	67.27	-30.26	-52.71
520	0.646	7.01	1.406	69.25	-34.16	-52.51
530	0.702	6.74	1.352	69.26	-38.39	-52.48
540	1.097	7.01	1.377	70.69	-39.73	-51.85
550	1.511	7.00	1.377	70.59	-41.21	<-60

RD07MVS1 Equivalent Circuit (@f=450-520MHz)

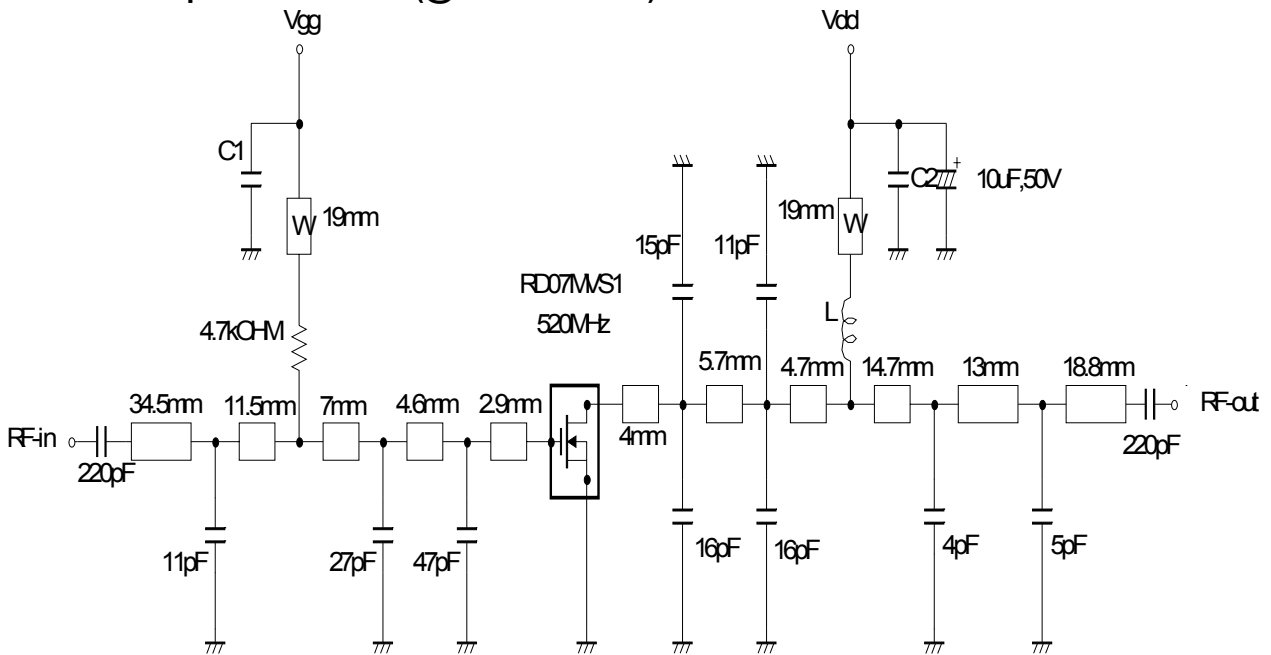

L 34.5nH Enamelled wire 5Turns, D:0.43mm, 246mm OD

C1, C2 1000pF, 0.022μF in parallel

Note: Board material- Teflon substrate

Microstrip line width=2.2mm/50Ω,  $\epsilon_r=2.7$ ,  $t=0.8$ mm

Wire width=1.0mm

