

Document NO. AN-900-026-A
 Date : 21st Feb. 2007
 Rev.date : 7th Jan. 2010
 Prepared : K. Mori
 Confirmed : S. Kametani
 (Taking charge of Silicon RF by
 Miyoshi Electronics)

SUBJECT: Recommendation of the output power control for RA45H7687M1

GENERAL:

Figure 1 shows recommended output power control of RA45H7687M1, which can be controlled by V_{GG2} and P_{in} adjusters.

RF OUTPUT of RA45H7687M1 can be controlled from about 1.5W to 45W by applying this system.

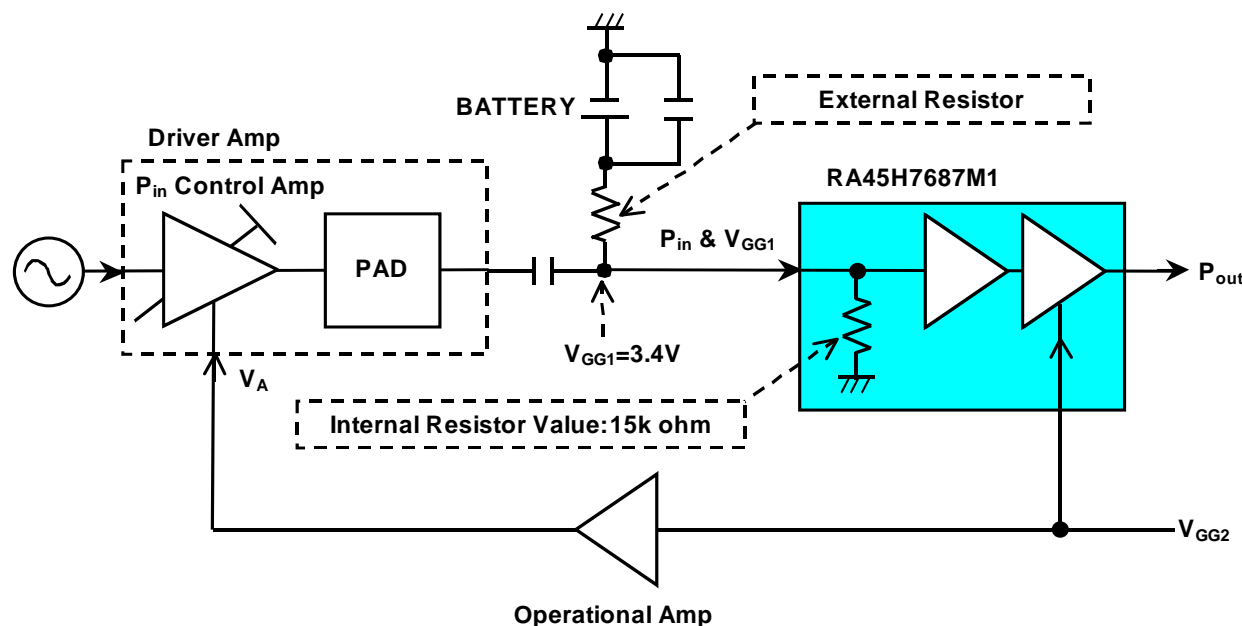

Figure 1 Recommended output power control block diagram for RA45H7687M1

1 How to supply V_{GG1}

The internal resistor value in this module between V_{GG1} , where RF is input, and ground is equal to 15k ohm as shown in figure 1. DC voltage between V_{GG1} and ground has to be fixed at 3.4V (tolerance=7%) to keep minimum performance. So, it is necessary that the external resistor value and the battery voltage shown in fig.1 should be set accurately. A design example of the external resistor value (ERV) and the battery voltage (BV) is indicated below.

$$ERV = 15000\text{ohm} / 3.4V \times BV - 15000\text{ohm} \quad (1)$$

$$V_{GG1} = 15000\text{ohm} \times BV / (ERV + 15000\text{ohm}) \quad (2)$$

For example, when BV shall be set at 5V, ERV is putting 5V into equation 1 gives 7k ohm. In this case, V_{GG1} in practice is around 3.41V from calc. of equation 2 if we choose ERV=7k ohm, and matches the V_{GG1} standard (i.e. $3.162V < \text{available-}V_{GG1} < 3.638V$).

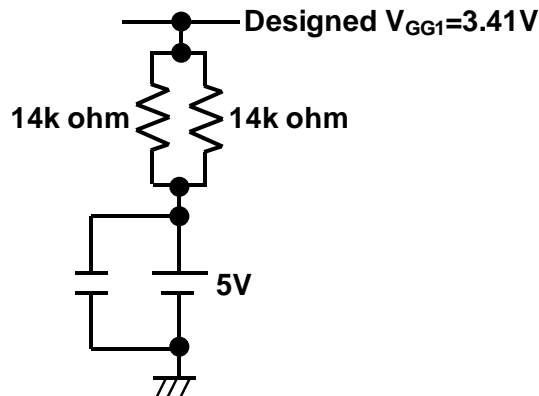

Figure 2 An example of designed V_{GG1}

2 Adjusters operation

As for adjusters (i.e. P_{in} and V_{GG2}), figure 3 shows recommended performance.

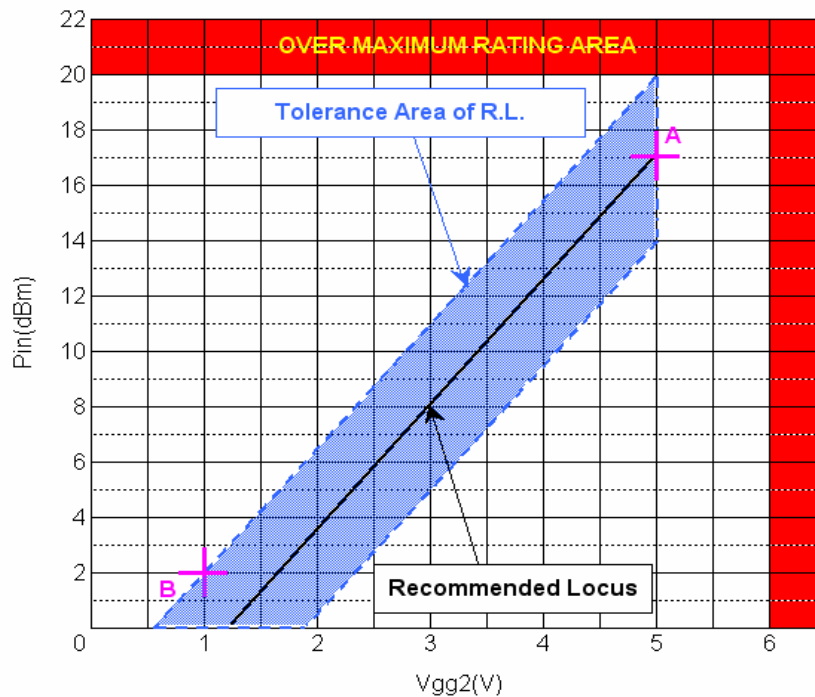

Figure 3 Recommended the link between P_{in} and V_{GG2} for RA45H7687M1

The point A, B in figure 3 shows each condition of output power in table 1 which is defined by the standard of this module.

Table 1

SYMBOL	PARAMETER	CONDITIONS	MIN	TYP	MAX	UNIT
P_{out1}	Output Power 1	$V_{DD}=12.8V, V_{GG1}=3.4V, V_{GG2}=5V, P_{in}=17dBm$	45			W
P_{out2}	Output Power 2	$V_{DD}=15.2V, V_{GG1}=3.4V, V_{GG2}=1V, P_{in}=2dBm$			1.5	W

Therefore, the locus of figure 3, the link condition between P_{in} and V_{GG2} , should cross point A and not tangent to point B.

We indicate the recommended locus which is based on above condition in this graph.

P_{in} and V_{GG2} which go through this locus is most suitable to get stable output power i.e. $1.5W < P_{out} < 45W$ at 764-to-870-MHz.

By employing this locus, electrical characteristics, such as P_{out} , total efficiency (ηT), P_{in} and V_{GG2} , are roughly evaluated as below by using contour map shown in the next section.

Table 2 Roughly evaluated values at $P_{out}=1.5W$

Freq. [MHz]		764	785	806	835	870
Adjusters	P_{in} [dBm]	7.3	4.9	4.0	6.2	7.1
	V_{GG2} [V]	2.9	2.3	2.1	2.6	2.8
Electrical Characteristic	ηT [%]	10	10	8	9	8
	2SP [dBc]	<-65	<-65	<-65	<-65	<-65
	3SP [dBc]	<-65	<-65	<-65	-44	-45

Table 3 Roughly evaluated values at $P_{out}=19W$

Freq. [MHz]		764	785	806	835	870
Adjusters	P_{in} [dBm]	9.8	8	8.5	10.3	10.9
	V_{GG2} [V]	3.4	3	3.1	3.5	3.7
Electrical Characteristic	ηT [%]	30	30	30	30	28
	2SP [dBc]	-59	-58	-65	<-65	<-65
	3SP [dBc]	<-65	<-65	<-65	-52	-52

Table 4 Roughly evaluated values at $P_{out}=45W$

Freq. [MHz]		764	785	806	835	870
Adjusters	P_{in} [dBm]	13.4	11.6	12.1	13.6	14.3
	V_{GG2} [V]	4.2	3.8	3.9	4.3	4.4
Electrical Characteristic	ηT [%]	42	42	42	41	40
	2SP [dBc]	-55	-54	-57	-60	<-65
	3SP [dBc]	<-65	<-65	-57	-46	-48

3 Contour map supporting RA45H7687M1 OUTPUT POWER CONTROL DESIGN

Followings are contour map for your information.

Recommendation of the output power control for RA45H7687M1

AN-900-026-A

CONTOUR MAP @ 764MHz

NOTE: P_{out} less than 20dBm is not accurate.

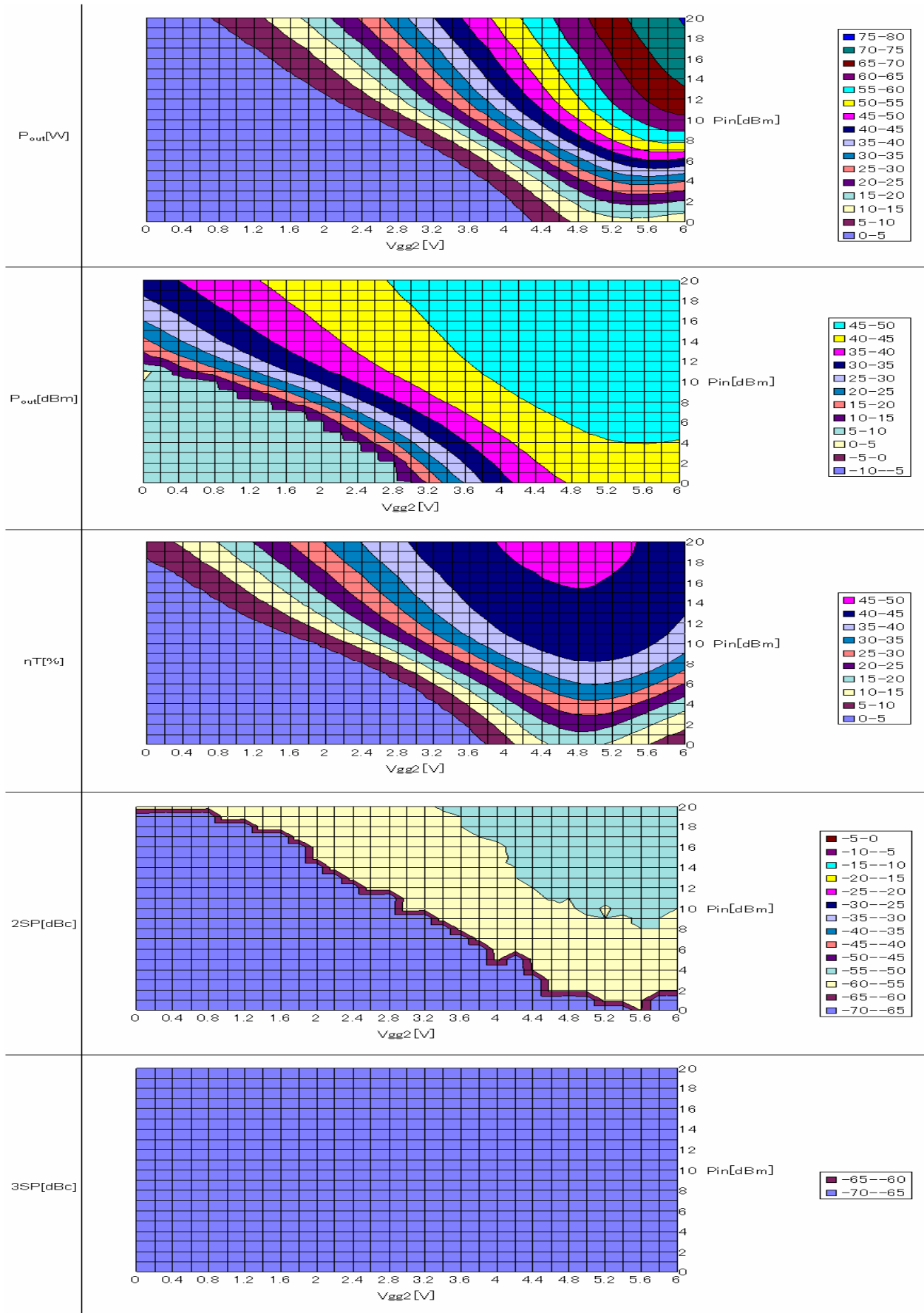

Recommendation of the output power control for RA45H7687M1

AN-900-026-A

CONTOUR MAP @ 785MHz

NOTE: P_{out} less than 20dBm is not accurate.

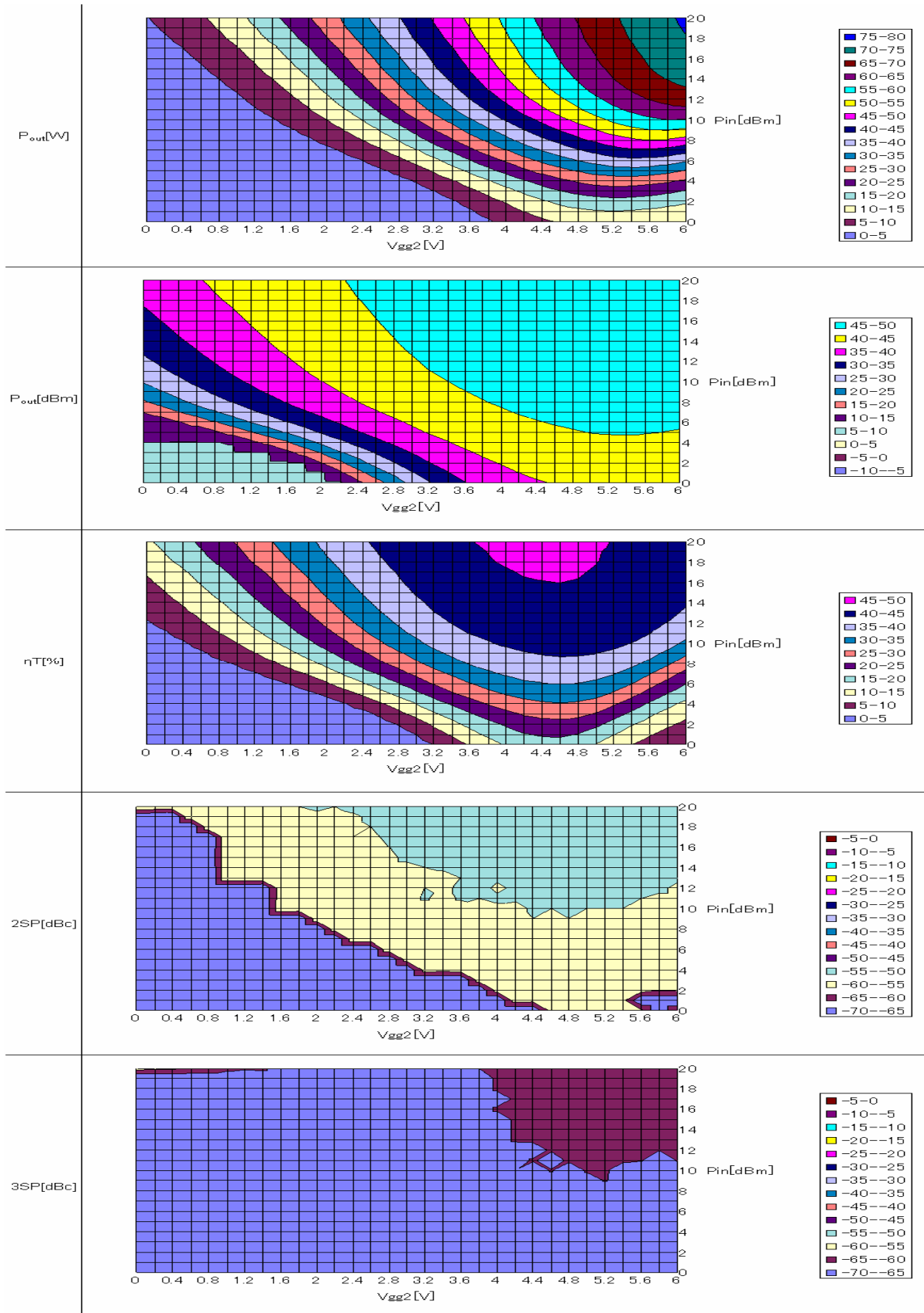

Recommendation of the output power control for RA45H7687M1

AN-900-026-A

CONTOUR MAP @ 806MHz

NOTE: P_{out} less than 20dBm is not accurate.

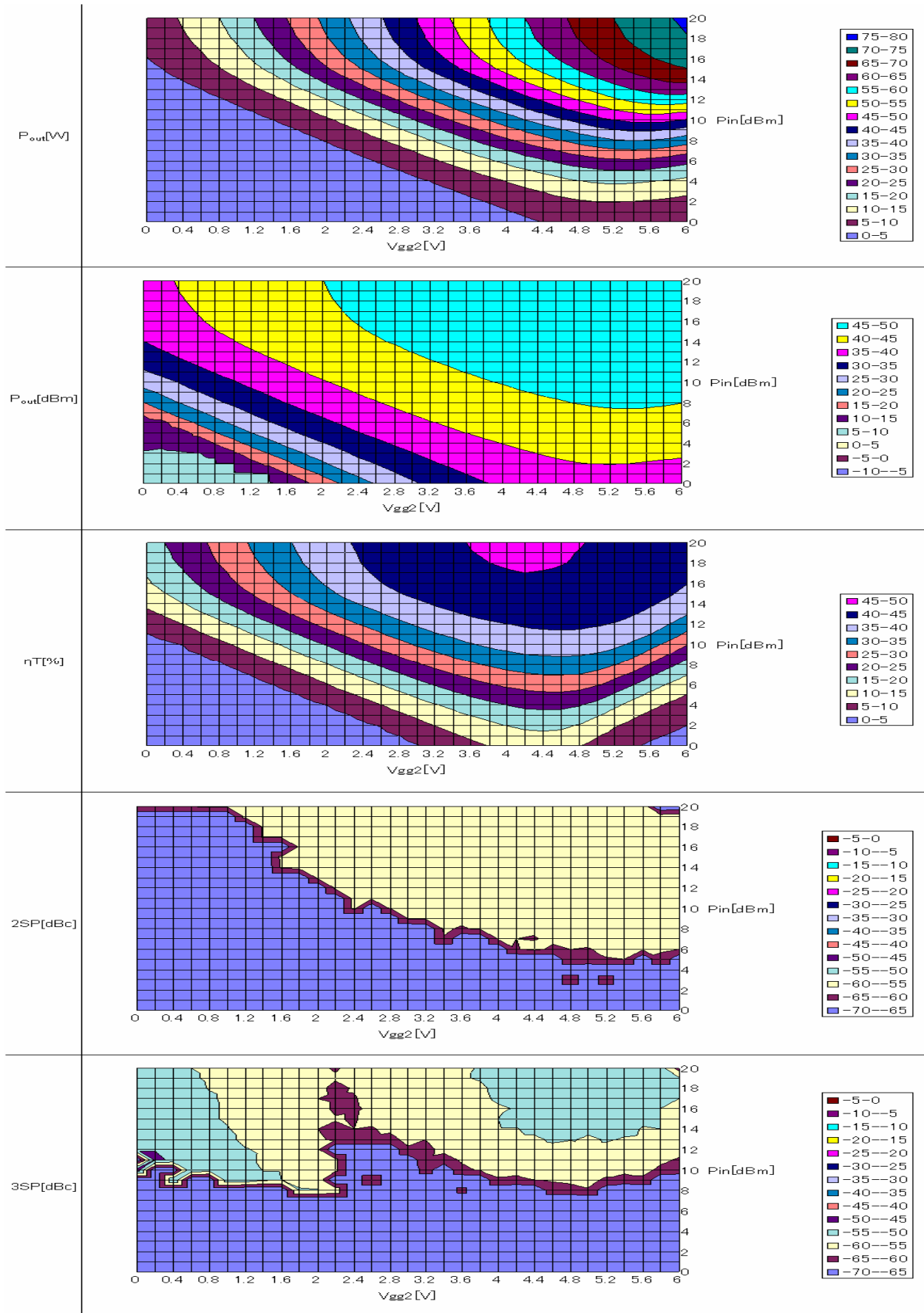

Recommendation of the output power control for RA45H7687M1

AN-900-026-A

CONTOUR MAP @ 835MHz

NOTE: P_{out} less than 20dBm is not accurate.

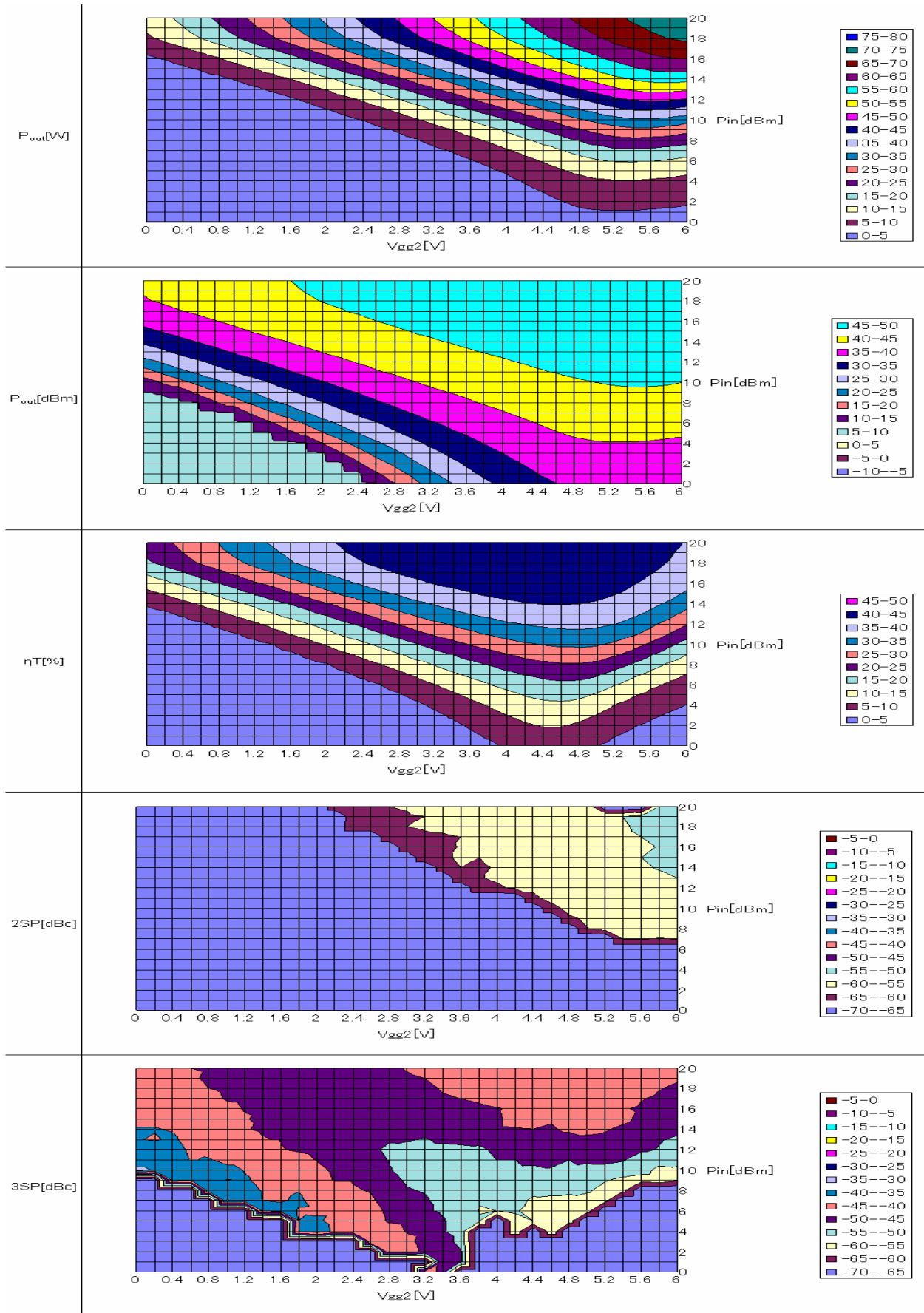

Recommendation of the output power control for RA45H7687M1

AN-900-026-A

CONTOUR MAP @ 870MHz

NOTE: P_{out} less than 20dBm is not accurate.

